

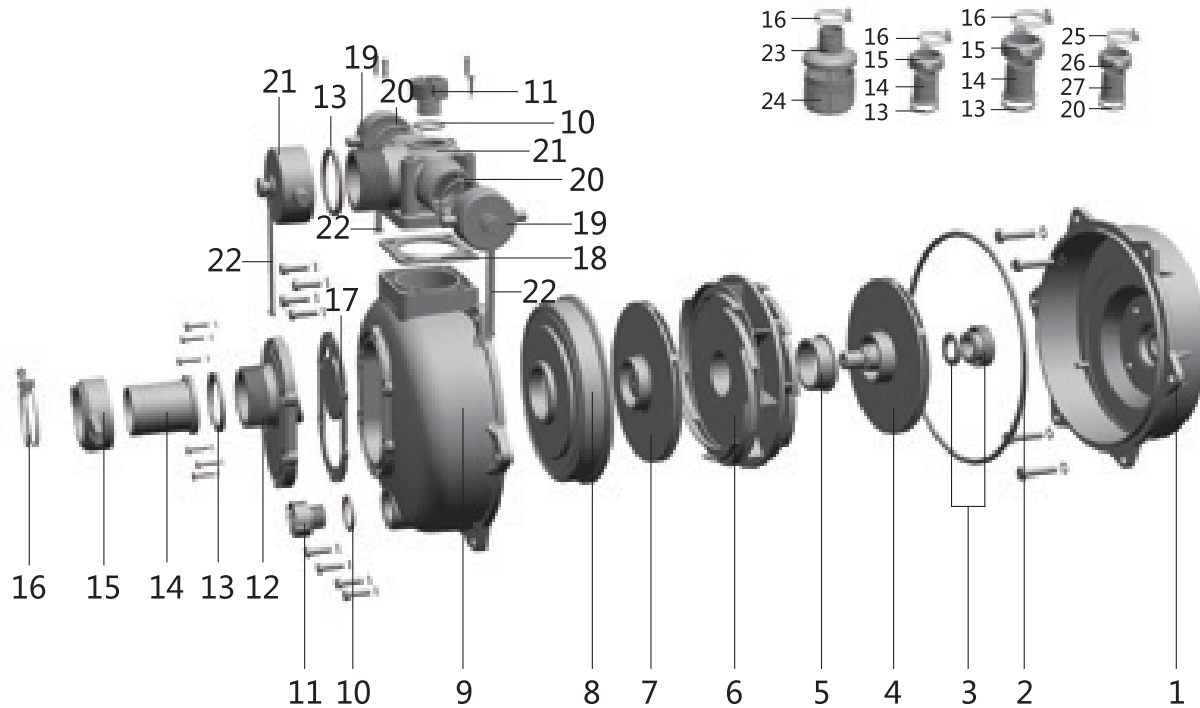

Model: HP20DUAL - 2" Twin Impeller Transfer Pump (Fire Fighter)



| Postion | Qty | Description |
|---------|-----|----------------------------|
| 1 | 1 | Pump Cover (Back Plate) |
| 2 | 1 | Pump Casing O-Ring |
| 3 | 1 | Mechanical Seal |
| 4 | 1 | Impeller #1 |
| 5 | 1 | Volute Bush |
| 6 | 1 | Dual Volute |
| 7 | 1 | Impeller #2 |
| 8 | 1 | Impeller Cover |
| 9 | 1 | Pump Body (Front Bowl) |
| 10 | 1 | Plug O-Ring |
| 11 | 2 | Plug |
| 12 | 2 | Inlet Flange |
| 13 | 2 | 2" Inlet Washer |
| 14 | 3 | 2" Hose Tail |
| 15 | 1 | 2" Hose Tail Locking Ring |
| 16 | 1 | 2" Hose Clamp |
| 17 | 1 | Check Valve |
| 18 | 1 | Outlet Gasket |
| 19 | 1 | 1½" Poly Cap |
| 20 | 3 | Outlet Washer |
| 21 | 1 | 2" Poly Cap |
| 22 | 1 | Rubber Cap Rope |
| 23 | 1 | 2" Filter Cover |
| 24 | 1 | 2" Filter Basket |
| 25 | 2 | 1½" Clamp |
| 26 | 2 | 1½" Hose Tail Locking Ring |
| 27 | 2 | 1½" Hose Tail |