

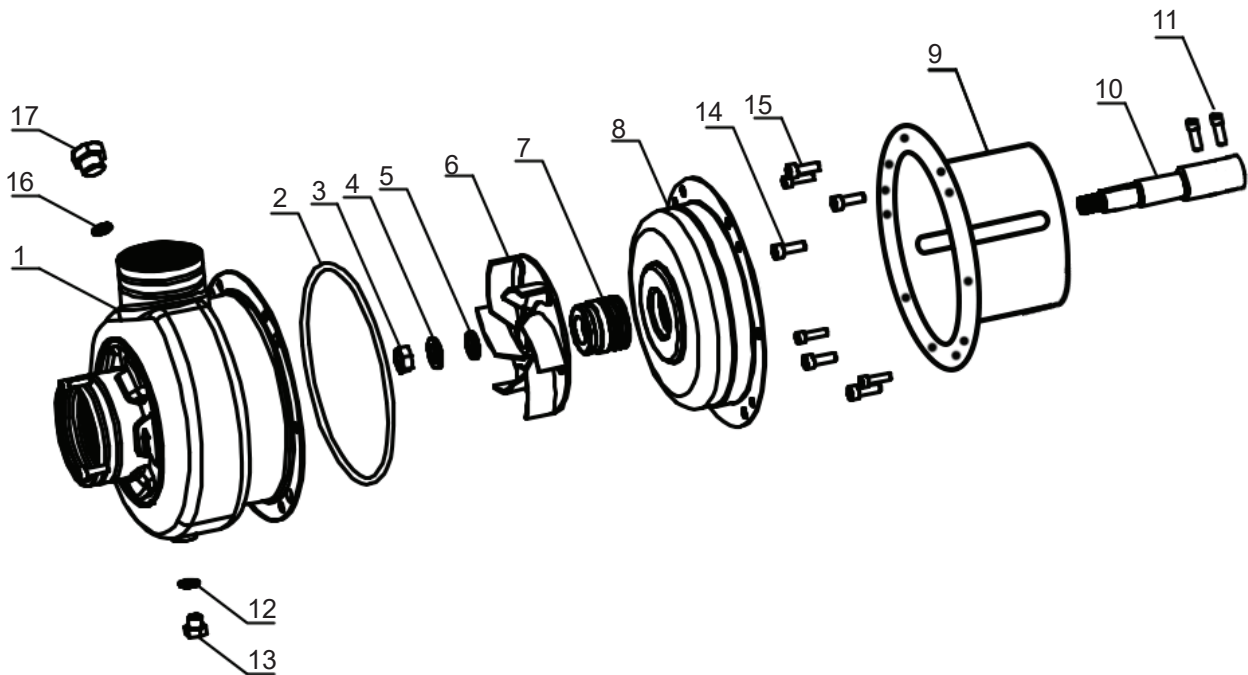

Model: NITRO SS - 2½" x 2" Stainless Steel Pump



Position	Qty	Description
1	1	Pump Cover (Front Bowl)
2	1	Casing O-Ring (Viton)
3	1	M12 Nut (316 Stainless Steel)
4	1	M12 Spring Washer (316 Stainless Steel)
5	1	M12 Plain Washer (316 Stainless Steel)
6	1	Impeller (316 Stainless Steel)
7	1	Mechanical Seal (Viton)
8	1	Volute (316 Stainless Steel)
9	1	Back Cover & Adaptor (Marine Grade Aluminium)
10	1	Adaptor Shaft (316 Stainless Steel)
11	4	Shaft Grub Screws (316 Stainless Steel)
12	1	Plug O-Ring (Viton)
13	1	Drainage Plug (316 Stainless Steel)
14	4	M5x12 Sockethead Casing Bolts (316 Stainless Steel)
15	6	Flange Bolts (M6x15 G316SS Bolt)
16	1	Plug O-Ring (Viton)
17	1	Filler Plug (316 Stainless Steel)
18	4	5/16 UNF x 1" Sockethead Bolt to GX200 Engine

Package Information

Model	Weight (KG)	L (mm)	W (mm)	H (mm)
NITROSS	3.5	260	210	210

